



**Mod.  
1716**

DS 1716-001B

LBT 8484

**MONITOR AIKO  
AIKO MONITOR  
MONITEUR AIKO  
MONITOR AIKO  
MONITOR AIKO**

**Sch./Ref. 1716/1 -/2**

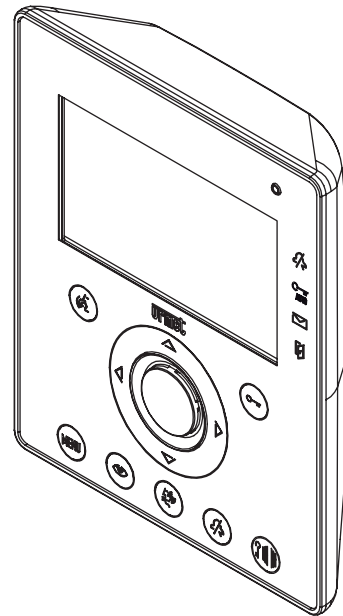

# ENGLISH

Aiko video door phones Ref. 1716/1 and Ref. 1716/2 are designed to be used in 2Voice systems.

## COMPONENTS DESCRIPTION AND CHARACTERISTICS

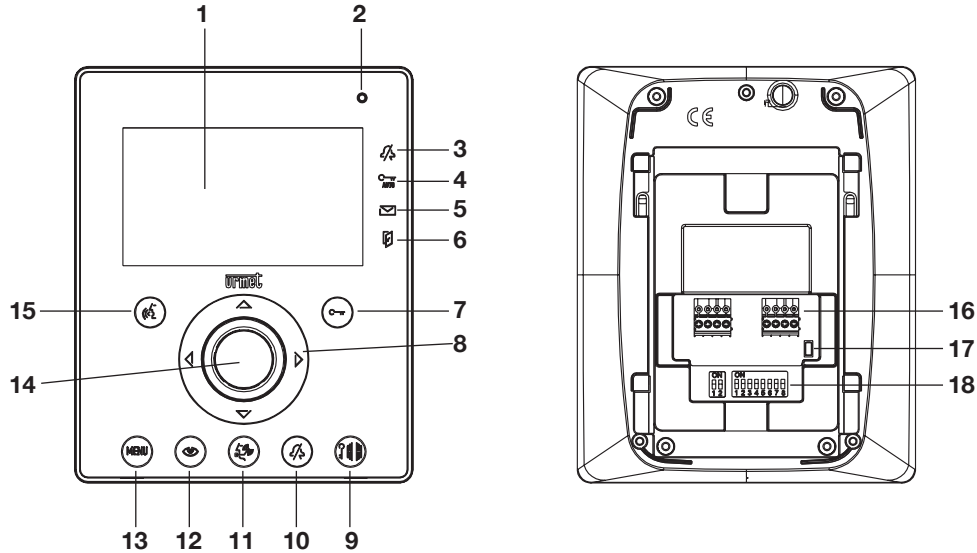

- 1 - Display
- 2 - Microphone
- 3 - Indication of "mute function" active (green led)
- 4 - Indication of automatic door lock release active (green led)
- 5 - Indication of present messages (green led)
- 6 - Indication of open door or absence active (red led)
- 7 - Door lock release button - Contextual button OK
- 8 - Navigation buttons
- 9 - Open main entrance button
- 10 - Mute ringer button (MUTE)
- 11 - Switchboard call button
- 12 - Automatic activation button
- 13 - Menu button
- 14 - Loudspeaker
- 15 - Button used to activate/deactivate audio - Contextual button X
- 16 - Terminal pins for connection to the system
- 17 - Line termination
- 18 - Configuration dip switch:
  - 2 to define the number of the apartment station inside the apartment
  - 8 to define the number of the apartment in the column

Aiko video door phone is provided with an embedded device for hard of hearing.

## INSTALLATION

Fix the flush mounting box at the height shown in the following figure. Fasten the bracket to the embedding box.

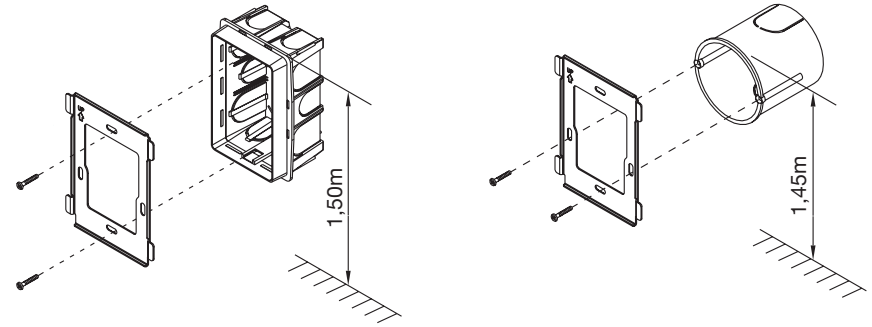

Perform connections and dip-switch settings. At the end of programming, fasten the video door phone to the bracket.

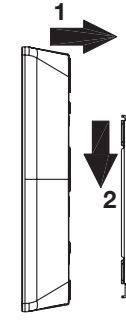

## TERMINAL PINS DESCRIPTION

- LINE IN** Connection to the system BUS
- LINE OUT** Connection to the next device for an in/out connection
- S+** Call repeat
- S-** Call repeat
- CP** Floor call

## CONFIGURATION OF APARTMENT STATIONS BRACKETS

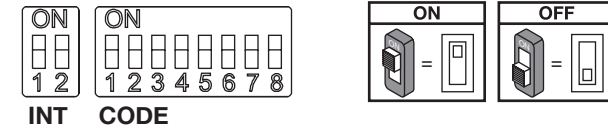

**Default values:** all video door phones default configuration is the following:  
 USER = 127  
 INTERNAL CODE = 0

Therefore, for the proper operation of the system, **always pay attention to dip switches, in order to configure them with the correct value.**

For dip switch settings, see the system manual provided with the power supply Ref. 1083/20.

**CODE:** user code.

Set a number from 0 to 127, according to the following rules:

- In the column there must not be any apartments with the same user code.
- If there are apartment stations in parallel in the same apartment, these must have the same user code.
- The user codes of the same column must be consecutive.

 To set the desired code, use the dip switches from 2 to 8 (2= most significant bit - 8= less significant bit); the dip-switch 1 must be set to OFF.

**INT:** apartment internal code.

Set a number from 0 to 3, according to the following rules:

- If in the apartment there is only one station, the internal code must be set to 0.
- In apartments, up to 4 apartment stations in parallel with the same user code and different internal codes can be connected.

The internal code identifies each station of the same user. This means that intercom calls can be addressed to the single internal code in the same apartment.

In case of intercom calls to different apartments, in case of calls coming from door units and in case of floor call, all the user apartment stations always ring. Consider also the following information:

- after receiving a call, the internal code 0 rings immediately; the internal codes 1, 2 and 3 ring in sequence.
- If the call comes from a video call station, the internal code 0 turns the monitor on.

However, the other apartment stations of the same user can press the button  to turn their video door phone, turning off the other ('video transfer' function).

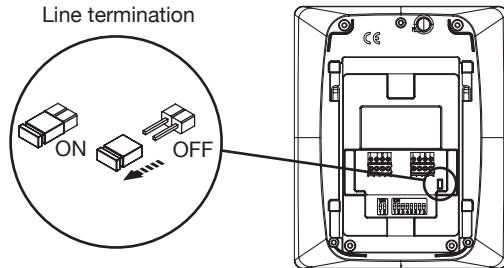
**LINE TERMINATION SETTING**

On the video door phone there is a jumper which allows to insert the line termination. The termination must be activated in all the devices installed at the end of a line that does not start again with another segment from the terminal pins LINE OUT:

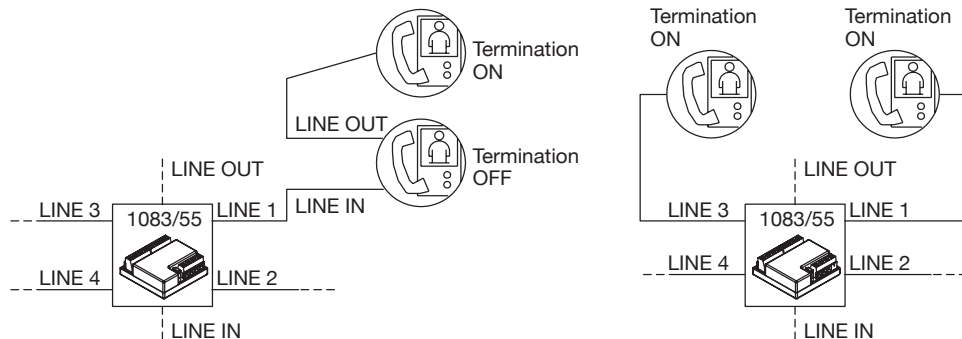
**CLEANING**

Clean the video door phone with a damp cloth, wiping gently the screen.

**FEATURES****CALL RECEPTION AND 'VIDEO TRANSFER' FUNCTION**

When a call is received, the user apartment station rings with the programmed tone, according to the source:

- From main door unit
- From secondary door unit
- From Intercom
- From floor call
- From switchboard

When the door phone or video door phone call is received, it is always possible to activate the door unit electric lock also without activating the communication.

If in the apartment there are several apartment stations in parallel, the stations ring in sequence. The user internal code 0 also performs the video door phone power-on, if the call comes from a video door phone call station. In this case, during the off-hook waiting time (60s from the call), the other internal codes can turn their video door phone on by pressing the auto-on button  ('video transfer' function), until one of the video door phones of the called user answers.

If the image is already displayed, press the button  to cyclically display images coming from other control cameras of the caller station only.



After the audio activation, the image coming from the main camera will be displayed only on the screen of the answering apartment station.

Therefore the camera image will be displayed on one apartment station at a time.

**ANSWERING THE CALL**



By pressing the button , the user establishes a communication with the caller (the button pressed starts blinking). By pressing again the button, the communication is closed and the display turns off.

**DOOR LOCK RELEASE DURING A CALL AND OPEN DOOR INDICATION**

After a call is received from a door unit or during the communication with a door unit, the pedestrian or driveway gate can be opened by pressing the buttons  and  respectively.

If the call modules are provided with open door sensor (and the absence service is not active), the led  can indicate if the door is really open or not: the led lights up steady if the open door is the main one, and blinks if the open door is the secondary one.

**RINGER LOUDSPEAKER MUTE**

This function allows to disabled the call ringer. To activate this function, press the button . When the function is activated, the led MUTE  turns on and when a call is received, the device will not ring.

**ADDITIONAL RINGER**

The video door phone is provided with two terminal pins (S+, S-) for the connection of an additional ringer or a relay. This ringer is activated with any call ring.

## AUDIO / VIDEO SETTINGS DURING CALL

When a call is received or during communication, some audio/video adjustments can be performed: by pressing the button **MENU**, the following screen appears

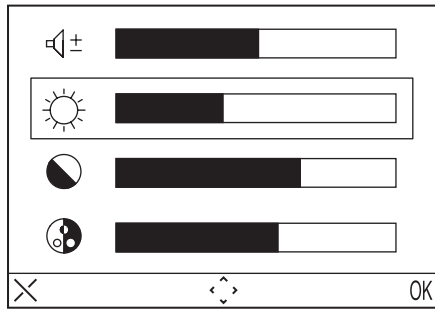

This menu will be displayed over the image coming from the door unit

- Select (Loudspeaker volume), (Brightness), (Contrast), (Colour) using directional buttons Up/Down.
- Select the desired value using directional buttons Right/Left
- Press (OK) to confirm; press (X) to cancel or press MENU to quit the setting menu.

## FLOOR CALL

The video door phone is equipped with a pair of terminal pins (CP) for the connection of a floor call button. When a floor call is received, the video door phone emits a ring, according to the ring tone selected by the user; the display does not turn on. If the user has several apartment stations in parallel, connect this button to only one apartment station. The internal codes will ring in sequence.

## AUTO-ON

The auto-on function allows to see on the display the image captured by system call modules. When the system is in standby mode, press the button and wait until the image is displayed on the video door phone (the first displayed image is the one coming from the main call module number 0); press again the button to go to the next call modules. The first images displayed are those coming from the main call modules, then secondary of the belonging column.

By activating the audio with the button , an audio and video communication is established with the selected call station; by pressing again the button , the auto-on function is ended.

The auto-on function can not be performed if the column is already in conversation. If the auto-on function is activated when the column is already in conversation, the video door phone will emit an alert tone.

## CALLING THE SWITCHBOARD

This function allows to establish a communication with the concierge switchboard: press the button to send the call to the switchboard. If there is no answer within 10s, the video door phone button will turn off and the call will be stored in the switchboard.

*The call to the switchboard is only AUDIO.*

## INTERCOM CALL

### Intercom call using the directory

The device allows to perform up to 32 intercom calls.

There are two types of intercom calls: intercom call inside the same apartment and intercom call outside the

apartment (the called device must be in the same column). To perform a call from the directory:

- Press the button **MENU** to access the menu.
- Select the icon and press OK.
- Select the user to be called with directional buttons and press OK.
- When the call is sent, the monitor turns off.

*If the system is busy, the user can not access the menu.*

### Intercom call using quick selection keys

The first 8 users of the video door phone directory can be called using quick selection keys; the first 8 users are associated to the buttons as follows:

User 1 -

User 2 -

User 3 -

User 4 -

User 5 -

User 6 -

User 7 -

User 8 -

To make an intercom call using the fast dial keys, press the push-to-talk button followed by one of the keys indicated above. Press again the push-to-talk button to close the conversation.

If the system is busy, the video door phone emits an alert tone.

*The intercom call is only AUDIO.*

## FUNCTIONING WITH HEARING AID

The video door phone is fitted with a device that allows hearing-impaired persons wearing a hearing aid to hear the person speaking from the call station or from another video door phone in the case of intercom calls. The device is able to interface hearing aids with "T" function at a distance of around 20 cm.

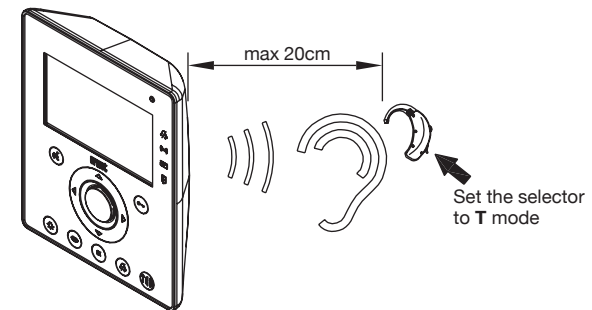

## MENU

To access the video door phone main menu, press the button **MENU**. The display shows:

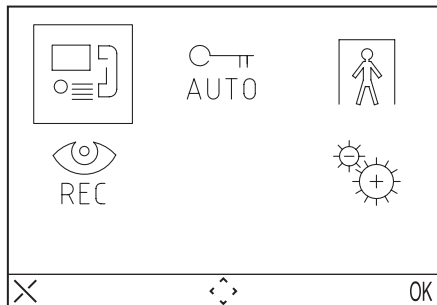

The device can return to standby mode at any moment by keeping the button X pressed for at least 3 seconds.

*If the column is already in conversation, the device will not turn on and emit an alert tone.*

## CALL MENU

With this menu the user can call a name previously saved in the directory.

- Press the button **MENU** to access the menu.
- Select the icon and press OK.
- Select the user to be called with directional buttons and press OK.
- When the call is sent, the monitor turns off.

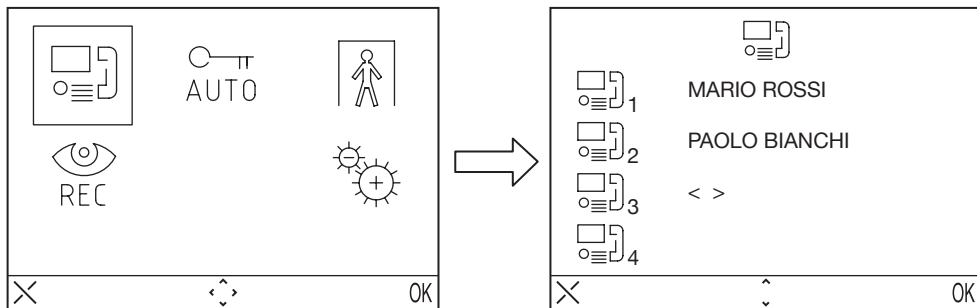

## AUTOMATIC DOOR LOCK RELEASE

The automatic door lock release function allows to directly open the door after receiving a call. To activate this function:

- Press the button **MENU** to access the menu.
- Select the icon and press OK. When the function is active, the LED turns on.

## ABSENCE INDICATION (For future development)

The absence indication service allows to inform the system about the absence of people inside the apartment. To activate this function from the video door phone with INT = 0:

- Press the button **MENU** to access the menu.
- Select the icon and press OK. When the function is active, the led blinks slowly.

## VIDEO DOOR PHONE ANSWERING MACHINE

If there are recorded video messages, the led blinks slowly. To receive messages:

- Press the button **MENU** to access the menu.
- Select the icon and press OK.

*This function is available only if the system is provided with the column video door phone answering machine.*

## SETTINGS

To access settings menu, press the button **MENU** and select the icon .

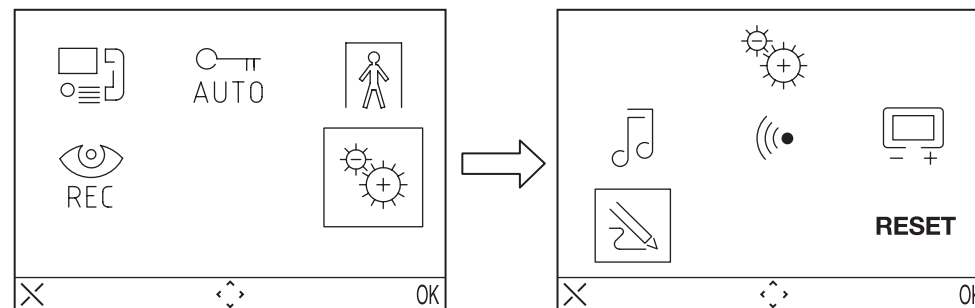

*If the system is busy, the user can not access the menu.*

## VIDEO DOOR PHONE DIRECTORY

Up to 32 calls can be included in the video door phone directory (calls to users and special calls).

### Adding a record to the directory

To add a name to the directory:

- Press the button **MENU** to access the menu.
- Select the icon and press OK.
- Select the icon , press OK and select the icon +.
- Select the record to be edited among the 32 available ones and press OK.
- Select the record, then select the function type to be configured and press OK; the possible functions are:
  - Internal call : call inside the same apartment
  - External call : call outside the apartment, but inside the same video door phone column.
  - Special request : Request to special decoder
- Enter the name to be assigned to the call, using directional buttons (Up and Down to select the character, Right and Left to move the cursor, X to delete) and press OK to confirm.
- Enter the code, using directional buttons (Up and Down to select the character, Right and Left to move the cursor, X to delete) and press OK to confirm.
  - For internal calls, allowable codes are from 0 to 3
  - For external calls, allowable codes are from 0 to 127
  - For special functions, allowable codes are from 0 to 250

### Changing a record in the directory



To change a record in the directory:

- Press the button **MENU** to access the menu.
- Select the icon and press OK.
- Select the icon , press OK and select the icon +.
- Select the record to be changed and press OK.

- After selecting the record, proceed as described in the previous paragraph “Adding a record to the directory”.





## Deleting a record of the directory

To delete a record in the directory:

- Press the button **MENU** to access the menu.
- Select the icon  and press OK.
- Select the icon , press OK and select the icon  - .
- Select the record to be deleted and press OK.





## CALL TONE SELECTION

In this menu the user can choose 5 different call tones for calls and floor calls. To select call tones:

- Press the button **MENU** to access the menu.
- Select the icon  and press OK.
- Select the icon , press OK.
- Select the call ring tone to be configured:  (call tone)  (floor call tone).
- Select the call ring tone to be used with directional buttons Right/Left.
- Press OK to confirm.







## AUDIO ADJUSTMENTS

In this menu, the user can adjust ringer volume, audio volume and buttons beep.

- Press the button **MENU** to access the menu.
- Select the icon  and press OK.
- Select the icon  and press OK.
- Select the icon  to adjust the ringer volume with directional buttons Right/Left, select  to adjust audio volume, and select BEEP to activate or not the button beep.
- After configuration, press OK to confirm.

## VIDEO ADJUSTMENTS

In this menu the user can adjust brightness, contrast, colour and themes (5 available themes) of the menu.

- Press the button **MENU** to access the menu.
- Select the icon  and press OK.
- Select the icon  and press OK.
- Select the icon  to adjust brightness with directional buttons Right/Left, select  to adjust contrast, select  to adjust colour and select  to adjust the desired theme.
- After configuration, press OK to confirm.

## RESET

In this menu the user can reset the device and restore all default configurations.

- Press the button **MENU** to access the menu.
- Select the icon  and press OK.
- Select the icon **RESET** and press OK.
- Select **YES** to confirm reset or select **NO** to go back.

 The Reset operation does not delete the directory.

## TECHNICAL CHARACTERISTICS

Power supply voltage:.....36 ÷ 48Vdc  
 Current consumption in standby:.....3mA max  
 Max. current consumption: .....160mA max  
 Operating temperature range:.....-5°C ÷ +45°C  
 Compliant with ..... EN61000-6-3, EN61000-6-1

Les vidéophones Aiko Réf. 1716/1 et Réf. 1716/2 ont été projetés pour être utilisés dans les systèmes 2Voice.

## DESCRIPTIONS DES PARTIES ET CARACTÉRISTIQUES

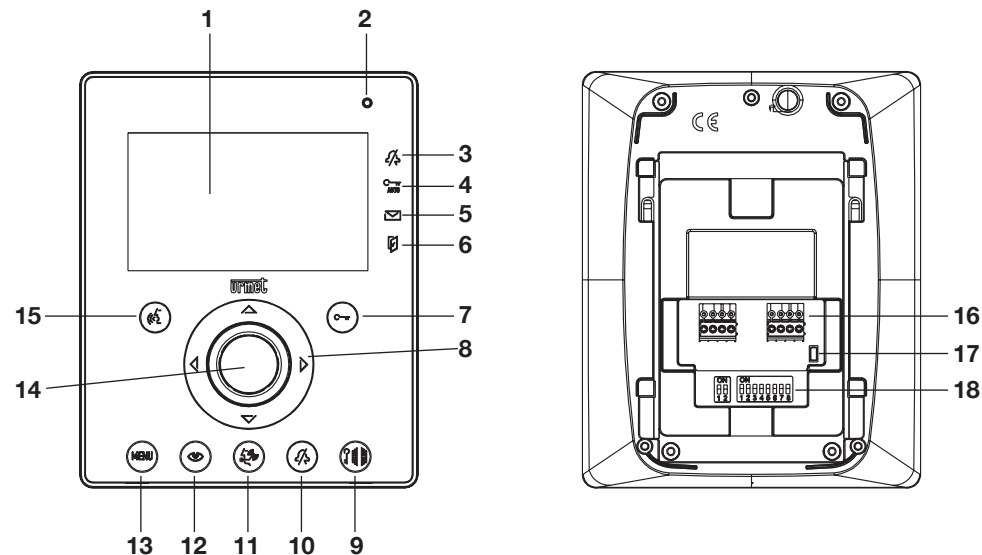

- 1 - Écran
- 2 - Microphone
- 3 - Indication de fonction «appel muet» (mute) actif (led verte)
- 4 - Indication d'ouvre-porte automatique actif (led verte)
- 5 - Indication de présence de messages (led verte)
- 6 - Indication de porte ouverte ou signal d'absence actif (led rouge)
- 7 - Touche ouvre-porte - Touche contextuelle OK
- 8 - Touches de navigation
- 9 - Touche d'ouverture de porte cochère
- 10 - Touche de désactivation sonnerie (MUTE)
- 11 - Touche d'appel du standard
- 12 - Touche d'auto-insertion
- 13 - Touche de Menu
- 14 - Haut-parleur
- 15 - Touche activation/exclusion de la phonie - Touche contextuelle X
- 16 - Bornes pour la connexion au système
- 17 - Terminaison de ligne
- 18 - Dip switch de configuration:
  - 2 pour définir le numéro du poste interne dans l'appartement
  - 8 pour définir le numéro du poste interne dans la colonne

 Le vidéophone Aiko est équipé avec un dispositif intégré pour les malentendants.

**DS 1716-001B**

URMET S.p.A.  
10154 TORINO (ITALY)  
VIA BOLOGNA 188/C  
Telef. +39 011.24.00.000 (RIC. AUT.)  
Fax +39 011.24.00.300 - 323



**LBT 8484**

Area tecnica  
servizio clienti +39 011.23.39.810  
<http://www.urmetdomus.com>  
e-mail: [info@urmetdomus.it](mailto:info@urmetdomus.it)

Fabbricato da Urmel Electronics Limited  
(azienda del gruppo Urmel) - Made in P.R.C.  
Manufactured by Urmel Electronics Limited  
(an Urmel group company) - Made in P.R.C.